

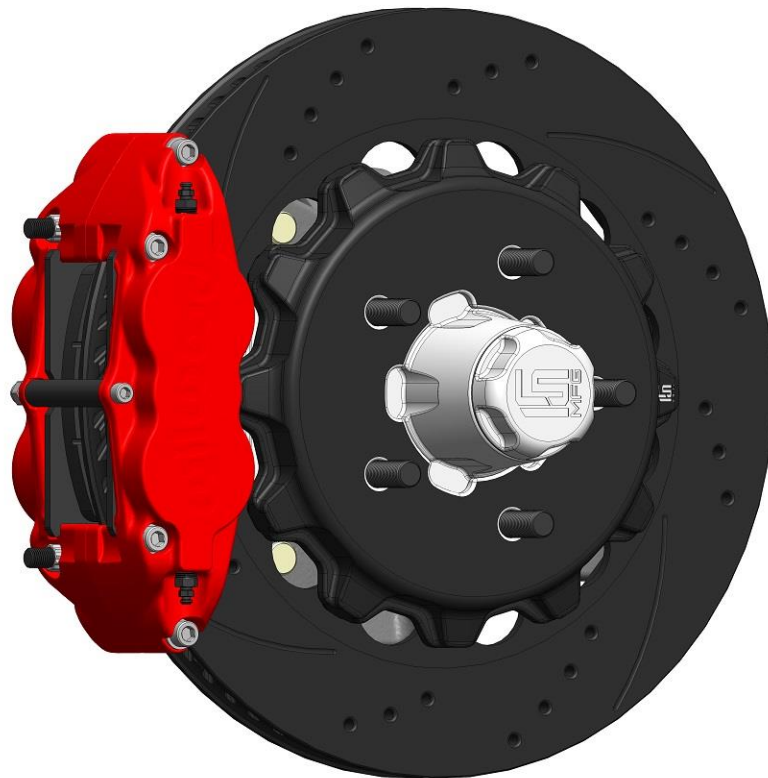

LSMFG / Wilwood
GM 1963-1987 C10 14" Front Big Brake Kit
(For Wilwood C10 Iron ProSpindles and CPP Modular)
BBK-210405, BBK-201209



Fitment

- 1963-1987 Chevrolet C10/R10 Pickup
- 1963-1991 Chevrolet C10/R10/R1500 Suburban
- 1963-1991 GMC C10//R10/R1500 Suburban
- 1963-1987 GMC C10/R10 Pickup
- 1969-1982 Chevrolet K5 Blazer (2wd)
- 1969-1982 GMC K5 Jimmy (2wd)

- Our 14" C10 kit utilizes Wilwood 6-piston FNSL calipers, machined aluminum hubs, hats, and radial brackets that bolt directly to the Wilwood C10 Iron ProSpindles and CPP Modular Spindles. Designed to fit 63-87 (and some models to 1991) full size 2wd GM trucks and SUVs.
- **Note:** Fits the Wilwood C10 Iron ProSpindle, part number 831-15931 and 831-15932. Model years 1963-72 will require updating to 1973-87 upper and lower ball joints, and tie rod ends, not included.
- **Note:** Fits the CPP Modular Spindle, part number CP30106-1, CP30106-2, CP30106-3, and CP30106-4. These spindles do not require the ball joints and outer tie rod ends to be swapped to 1973-87 versions, when the correct year range has been selected.
- It is the buyer's responsibility to check proper clearance and function of all brake parts to their existing suspension components and wheels/tires before driving the vehicle.

OE Hub Offset: Increase/Decrease Track Width	+ .24"
Caliper Type:	FNSL 6-Piston
Rotor Diameter:	14"
Min. Wheel Diameter:	18"
Spindles:	Requires Wilwood C10 Iron ProSpindle, part number 831-15931 and 831-15932, or CPP Modular Spindle part number CP30106-1, CP30106-2, CP30106-3, and CP30106-4

Wheel Clearance Diagram

Dotted line represents the caliper body

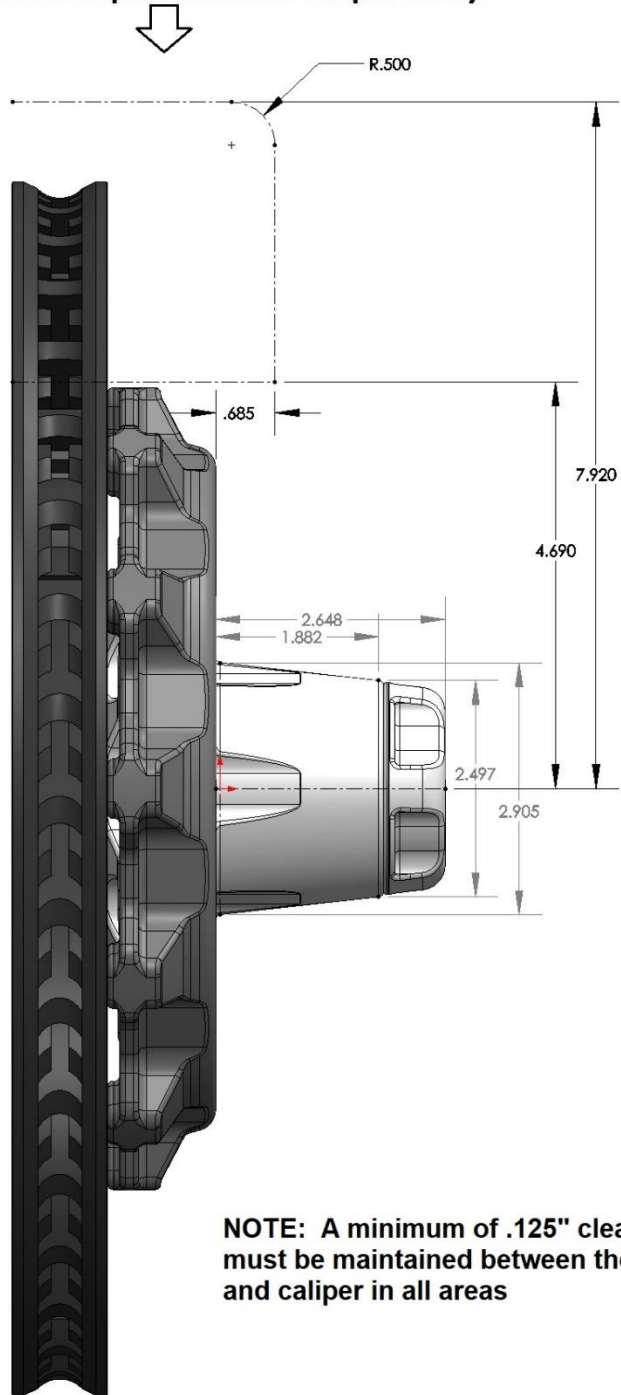

Warning

- Disc brakes should only be installed by someone experienced and competent in the installation and maintenance of disc brakes.
- If you are not sure of how to safely use this brake component or kit, you should not install or use it.
- Do not assume anything. Improperly installed or maintained brakes are dangerous. If you are not sure, get help or return the product.

Notes

- As with most suspension and tire modifications (from OEM specifications), changing the brakes may alter the front to rear brake bias. Your specific needs will depend on other modifications to the system.
- For added user control, the factory proportioning valve can be swapped to an adjustable proportioning valve such as [Wilwood 260-10922](#) or [Wilwood 260-11179](#). Installation of a Wilwood adjustable proportioning valve will require brake line work on your end to install since it is not a direct swap.
- Stainless steel braided hoses are necessary for the installation of this kit. They are available to fit the factory chassis fittings here: [Braided Stainless Hoses - 63-91 GM C10/K10 for 14/16 inch Front Kits](#)
- This kit fits most 18-inch diameter wheels and larger.
- Use of Loctite® 271 to all threaded bolts is recommended.
- The wheel position is moved outboard .24" from its stock position.
- It is the responsibility of the buyer and installer of this kit to verify suitability/fitment of all components and ensure all fasteners and hardware achieve complete and proper engagement. Improper or inadequate engagement can lead to component failure.



Note: Fits the Wilwood C10 Iron ProSpindle, part number 831-15931 and 831-15932. When using these spindles, model years 1963-72 will require updating to 1973-87 upper and lower ball joints, and tie rod ends, not included.

This kit also fits the CPP Modular Spindle, part number CP30106-1, CP30106-2, CP30106-3, and CP30106-4. These spindles **do not** require the ball joints and outer tie rod ends to be swapped to 1973-87 versions, when the correct year range has been selected.

The installation steps shown refers to the **passenger side** spindle. All steps are to be repeated on the driver side. For instruction purposes, the spindle is shown as removed, but this installation can be done with the spindle installed on the truck.

In instances where the stock spindle is being replaced, you have 2 options:

- You can remove the spindle, rotor, and caliper as one assembly. Start by clamping off the factory brake hose (which is not reused for big brake kits), then remove the hose from the caliper. You can then follow best practices for removing the spindle/brake assembly from the truck. Install new spindle per OEM instructions.
- Remove the components individually. Start by clamping off the factory brake hose (which is not reused for big brake kits), remove the hose from the caliper, and the caliper from the spindle. Remove the factory dust cap, then cotter pin, castle nut, and washer. You can now remove the rotor from the spindle to access and remove the 3 dust shield bolts underneath. You can then follow best practices for removing the spindle from the truck. Install new spindle per OEM instructions.

2

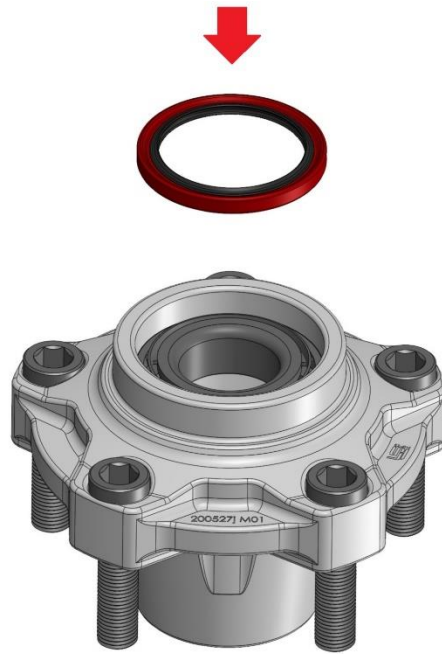

Pack the large inner bearing (A5) with high temperature disc brake bearing grease and install into the back side of the hub. The inner seal can then be pressed in or lightly tapped in with a hammer by circling the perimeter.

3 & 4



You can now install the hub onto the spindle, then pack the outer bearing (A3) with grease and install under the factory washer, castle nut, and supplied cotter pin. After bending the leg of the cotter pin, install the machined dust cap as shown.

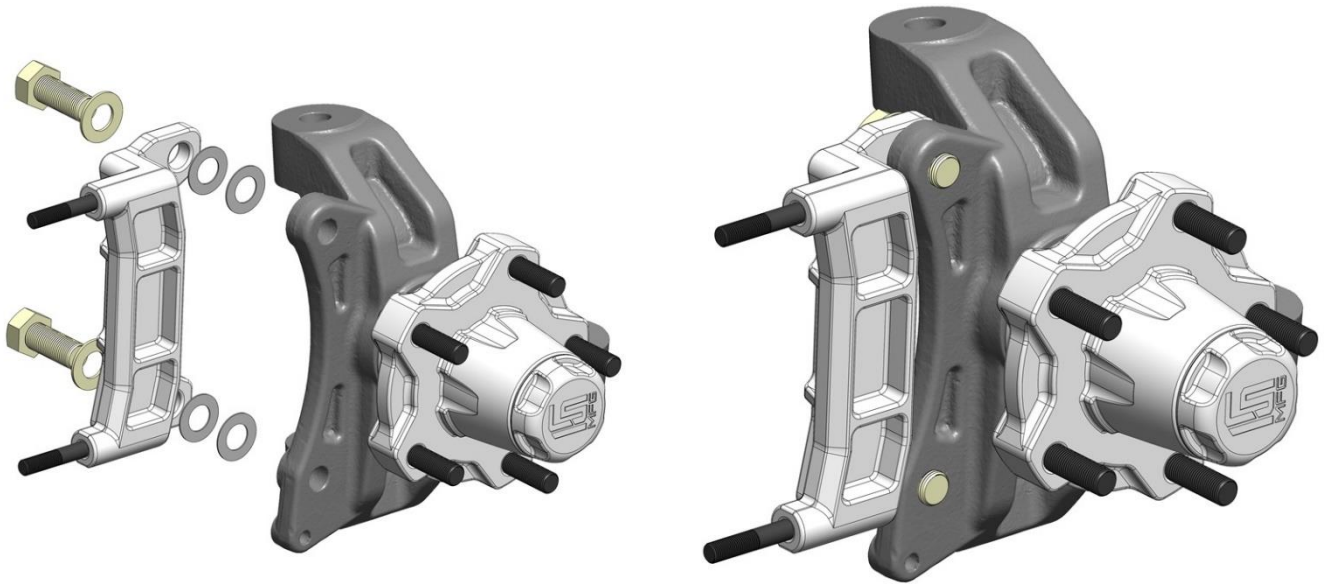

The radial bracket can temporarily be installed at this time using the supplied bolts with flat washers and two .750x.438x.030 shim washers between the bracket and spindle. It is not necessary to torque them at this time.

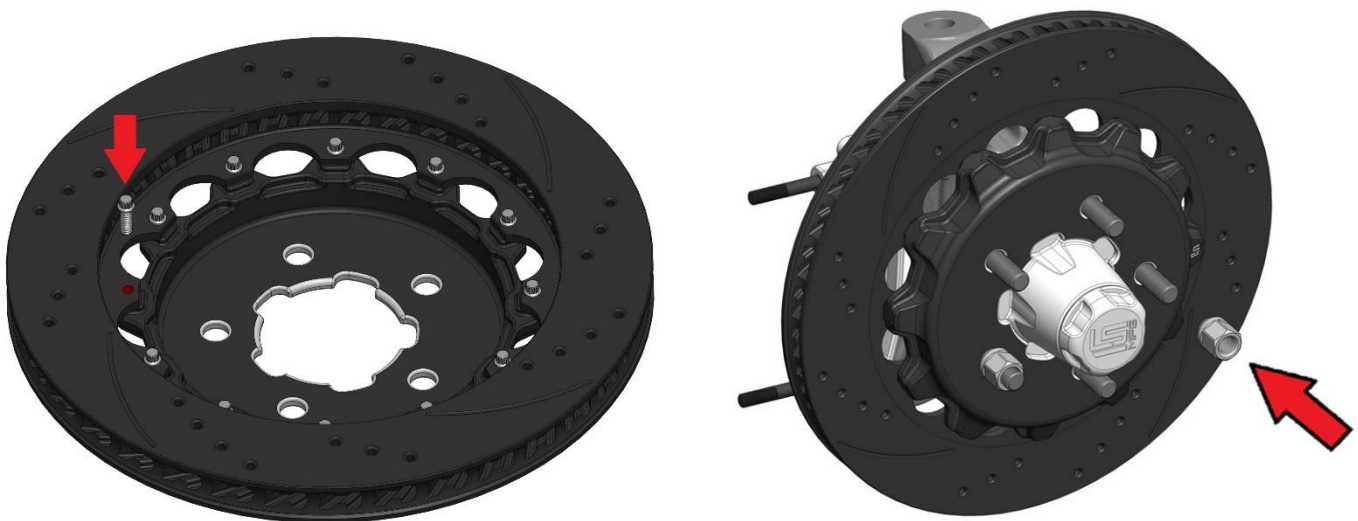

Arrange the rotor and hat in the position shown ensuring the arrow noting rotation direction is correct for its position on the vehicle. Note that the hat should be installed on the flat side of the rotor. Start the first few threads of all 12 of the ¼-20 12-point bolts. Using an alternating sequence, apply red Loctite® 271 to the threads, and torque to **155 in-lbs**. The rotor can be installed on the hub at this time using two lug nuts to hold the hat flat against the hub.

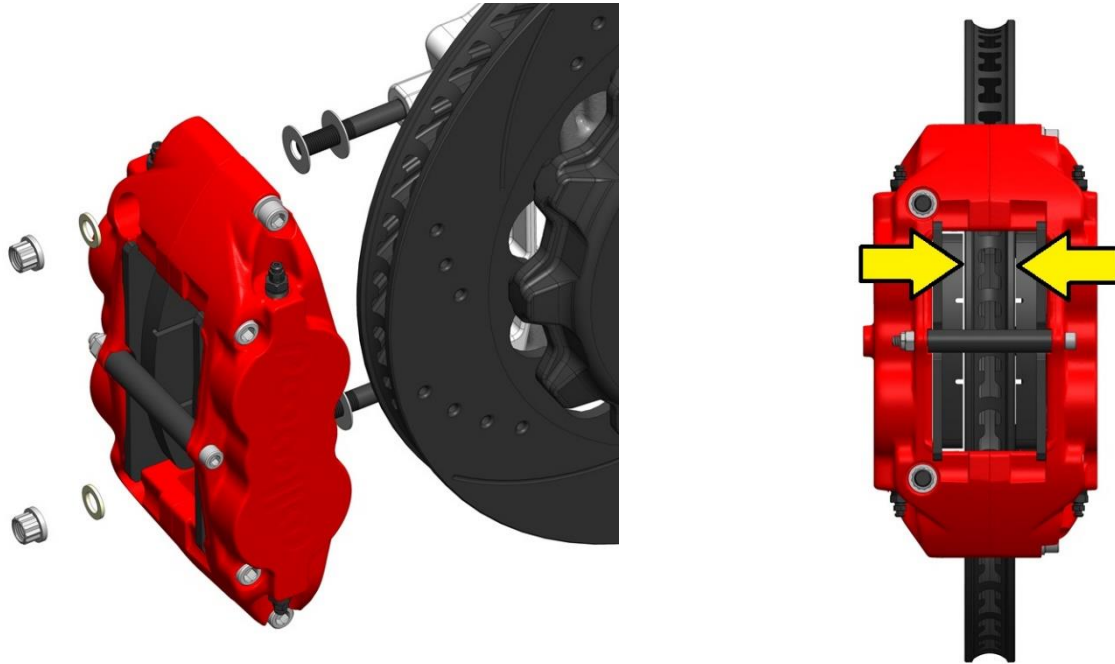

This kit contains distinct right and left-hand calipers that must be mounted in the correct direction. They should be positioned so that the largest pistons are at the rotor exit end of the caliper. There is an arrow on the face of the caliper noting rotation direction. Lubricate the caliper mounting studs with lightweight oil. Initially place two .875x.375x.035 shim on each stud of the bracket. Mount the caliper using lock nuts and washers and ensure that it seats on the bracket and does not contact the spindle.

Remove the bridge bolt, nut, and spacer tube and install the pads at this time. Temporarily tighten the lock nuts and view the rotor through the top opening of the caliper. The caliper will need to be centered on the rotor by adding or subtracting the .750x.438x.030 shims between the bracket and the spindle. Always use the same amount of shims on each of the two mounting bolts.

Once the caliper alignment is correct side to side, check that the top of the brake pads are flush with the outside diameter of the rotor. If not, adjust by adding or subtracting .875x.375x.030 shims between the caliper and bracket.

After the caliper pad height is set, check that there is no pre-applied pressure when spinning the rotor. If so, make adjustments as necessary. Then remove the bracket mounting bolts one at a time, apply red Loctite® 271 to the threads, and torque to **80 ft-lbs**. Torque the caliper lock nuts to **30 ft-lbs**. Then secure the brake pads in place with the center bridge pad retainer tube, bolt, and locknut. The locknut should be snug without play in the bolt or tube. However, be cautious not to over tighten.

Temporarily install the wheel and tighten the lug nuts. Ensure that the wheel rotates freely without any interference or contact to the caliper.



OEM rubber brake hoses generally cannot be adapted to Wilwood calipers. These Wilwood calipers utilize a 1/8 NPT fitting. **DO NOT** thread any OEM tube-nuts into the caliper directly without adapting to 1/8 NPT.

LSMFG provides [Braided Stainless Hoses - 63-91 GM C10/K10 for 14/16 inch Front Kits](#) to go between the caliper and the factory hard line fittings at the chassis. When used, apply a small amount of thread sealant such as Loctite® 545 to the adapter fitting before installing the adapter into the caliper.

Note: It is the installer's responsibility to confirm that all fittings and hoses are the correct size and length, to also to ensure proper sealing and that they will not be subject to crimping, strain and abrasion from vibration or interference with suspension components, the brake rotor, or wheel. In absence of specific instructions for brake line routing, the installer must use their best professional judgment on correct routing and retention of lines to ensure safe operation. After properly bleeding your brake system, test the system per the "Brake Testing" procedure stated within this document before driving. After road testing, inspect for leaks and interference. Initially after install and testing, perform frequent checks of the vehicle brake system and lines before driving to confirm that there is no undue wear or interference not apparent from the initial test. Afterwards, perform periodic inspections for function, leaks and wear in an interval relative to the usage of vehicle.

Additional Information and Recommendations

- As with most suspension and tire modifications (from OEM specifications), changing the brakes may alter the front to rear brake bias. Rear brakes should not lock up before the front. Brake system evaluation and tests should be performed by persons experienced in the installation and proper operation of brake systems. Evaluation and tests should be performed under controlled conditions. Start by making several stops from low speeds then gradually work up to higher speeds. Always utilize safety restraint systems while operating the vehicle.
- For optimum performance, fill and bleed the new system with Wilwood Hi-Temp^o 570 grade fluid or EXP 600 Plus. For severe braking or sustained high heat operation, use Wilwood EXP 600 Plus Racing Brake Fluid. Used fluid must be completely flushed from the system to prevent contamination. **Note:** Silicone DOT 5 brake fluid is **NOT** recommended for racing or performance driving.
- To properly bleed the brake system, begin with the caliper farthest from the master cylinder. Bleed the outboard bleed screw first, then the inboard. Repeat the procedure until all calipers in the system are bled, ending with the caliper closest to the master cylinder. If the caliper is fitted with bleed screws on four corners, make sure the bottom bleed screws are tight. Only bleed from the top bleed screws. **Note:** When using a new master cylinder, it is important to bench bleed the master cylinder first.
- Test the brake pedal. It should be firm, not spongy, and stop at least 1 inch from the floor under heavy load. If the brake pedal is spongy, bleed the system again. If the brake pedal is initially firm, but then sinks to the floor, check the system for leaks. Correct the leaks (if applicable) and then bleed the system again. If the brake pedal goes to the floor and continued bleeding of the system does not correct the problem, either air may be trapped in the system, or a master cylinder with increased capacity (larger bore diameter) may be required.

Brake Testing

- Make sure your pedal is firm: Hold firm pressure on pedal for several minutes, it should remain in position without sinking. If pedal sinks toward floor, check system for fluid leaks. **DO NOT** drive the vehicle if pedal does not stay firm or can be pushed to the floor with normal pressure.
- At a very low speed (2-5 mph) apply brakes hard several times while turning steering from full left to full right, repeat several times. Remove the wheels and check that components are not touching, rubbing, or leaking.
- Carefully examine all brake components, brake lines, and fittings for leaks and interference. Make sure there is no interference with wheels or suspension components.
- Drive the vehicle at a low speed (15-20 mph) making moderate and hard stops. Brakes should feel normal and positive. Again, check for leaks and interference.
- Always test vehicle in a safe place where there is no danger to (or from) other people or vehicles.
- Always wear seat belts and make use of all safety equipment.

Pad and Rotor Bedding

- Once the brake system has been tested and determined safe to operate the vehicle, follow these steps for the bedding of the pads and rotors. These procedures should only be performed on a racetrack, or other safe location where you can safely and legally obtain speeds up to 65 MPH, while also being able to rapidly decelerate.
- Begin with a series of light decelerations to gradually build some heat in the brakes. Use an on-and-off the pedal technique by applying the brakes for 3-5 seconds, and then allow them to fully release for a period roughly twice as long as the deceleration cycle. If you use a 5-count during the deceleration interval, use a 10-count during the release to allow the heat to sink into the pads and rotors.
- After several cycles of light stops to begin warming the brakes, proceed with a series of medium to firm deceleration stops to continue raising the temperature level in the brakes.
- Finish the bedding cycle with a series of 8-10 hard decelerations from 55-65 MPH down to 25 MPH while allowing a proportionate release and heat-sinking interval between each stop. The pads should now be providing positive and consistent response.
- If any amount of brake fade is observed during the bed-in cycle, immediately begin the cool down cycle.
- Drive at a moderate cruising speed, with the least amount of brake contact possible, until most of the heat has dissipated from the brakes. Avoid sitting stopped with the brake pedal depressed to hold the car in place during this time. Park the vehicle and allow the brakes to cool to ambient air temperature.

COMPETITION VEHICLES: If your race car is equipped with brake cooling ducts, blocking them will allow the pads and rotors to warm up quicker and speed up the bedding process. Temperature indicating paint on the rotor and pad edges can provide valuable data regarding observed temperatures during the bedding process and subsequent on-track sessions. This information can be highly beneficial when evaluating pad compounds and cooling efficiencies.

POST-BEDDING INSPECTION: After the bedding cycle, the rotors should exhibit a uniformly burnished finish across the entire contact face. Any surface irregularities that appear as smearing or splotching on the rotor faces can be an indication that the brakes were brought up to temperature too quickly during the bedding cycle. If the smear doesn't blend away after the next run-in cycle, or if chatter under braking results, sanding or resurfacing the rotors will be required to restore a uniform surface for pad contact.

For any questions or suggestions, please [CONTACT US](#)

